

PATROL CAB CHASSIS

SHIFT the way you move



Specifications

	DX Coil 3.0 litre intercooled turbo diesel	DX Leaf 3.0 litre intercooled turbo diesel	ST Coil 3.0 litre intercooled turbo diesel
Engine			
3.0 litre common-rail intercooled turbo diesel DOHC	•	•	•
Displacement (cc)	2953	2953	2953
Bore x stroke (mm)	96 x 102	96 x 102	96 x 102
Compression ratio	17.9:1	17.9:1	17.9:1
Max. power (kW@rpm) ECE	118@3200 - 3400	118@3200 - 3400	118@3200 - 3400
Max. torque (Nm@rpm)	380@2000 - 2400	380@2000 - 2400	380@2000 - 2400
Viscous Air cleaner element	•	•	•
Cyclone Air cleaner	•	•	•

Transmission			
Type	5-speed Manual	5-speed Manual	5-speed Manual
Gear ratios 1st	4.262	4.262	4.262
2nd	2.455	2.455	2.455
3rd	1.488	1.488	1.488
4th	1.000	1.000	1.000
5th	0.85	0.85	0.85
Rev	3.971	3.971	3.971
Rear axle ratio	4.111	4.111	4.111
Transfer case	2.02:1	2.02:1	2.02:1

Fuel			
Main fuel tank capacity	95 litres	95 litres	95 litres
Sub fuel tank capacity	80 litres	80 litres	80 litres

Mechanical			
Limited slip differential	•	•	•
Front ventilated disc brakes	•	•	•
Rear ventilated disc brakes	•	•	•
Rear drum brakes	•	•	•
Load sensing brake valve	•	•	•
Manual free wheeling hubs	•	•	•
Manual idle control	•	•	•
Power steering	•	•	•

Suspension			
Front - 3 link coil springs	•	•	•
Front stabiliser	•	•	•
Rear - 5 link coil springs	•	•	•
Rear stabiliser	•	•	•
Rear - progressive rate leaf springs	•	•	•
Semi floating rear axle	•	•	•
Full floating rear axle	•	•	•

Wheels/Tyres			
16x8JJ wheels with 265/75R16 LT tyres	•	Opt	•
5.5F x 16 wheels with 7.50R16 LT tyres	•	•	•

Dimensions			
Overall length (mm) (without tray)	4940	5115	4940
Overall width (mm) (without tray)	1940	1840/1940 [^]	1940
Overall height (mm) (without tray)	1875	1895/1875 [^]	1875
Wheelbase (mm)	2970	2970	2970
Turning Circle (m)	12.5	12.5	12.5
Turns of steering wheel (lock to lock)	3.4	3.5	3.4
Steering gear ratio	17.0	17.0	17.0

Rated Towing Capacity¹			
Trailer with/without brakes (kg)	3200/750	3200/750	3200/750
Towball download (kg)	See table	250	See table

	DX Coil 3.0 litre intercooled turbo diesel	DX Leaf 3.0 litre intercooled turbo diesel	ST Coil 3.0 litre intercooled turbo diesel
Weights			
Tare (without tray) (kg)	1997	2123	2009
Gross Vehicle Mass (GVM ²) (kg)	3150	3400	3150
Gross Combination Mass (GCM) (kg)	6200	6200	6200
Front axle capacity (kg)	1530	1530	1530
Rear axle capacity (kg)	1800	2650/2240 ⁴	1800

Interior			
Seating capacity	3	3	2
Front bucket seats	•	•	•
Driver bucket, passenger bench seat	•	•	•
Seat trim	Cloth	Cloth	Moquette
Power windows	•	•	•
Central locking	•	•	•
Tilt adjustable steering	•	•	•
Air-conditioning	•	•	•
AM/FM radio/CD	•	•	•
Antenna	Manual	Manual	Power
Speakers	2	2	2
Cigarette lighter	•	•	•
Ashtray	•	•	•
Door pockets	Large	Large	Large
Door trim inserts	Vinyl	Vinyl	Moquette
Door armrests	Small	Small	Large
Centre console with lid	•	•	•
Cup holders	•	•	•
Roof console with sunglasses holder	•	•	•
Map lights	•	•	•
4 spoke steering wheel	•	•	•
Passenger assist grips	•	•	•
Tinted glass (green)	•	•	•
Sunvisor	Vinyl	Vinyl	Vinyl
Floor covering	Vinyl	Vinyl	Carpet
Driver's footrest	•	•	•
Room lamp	•	•	•

Instrumentation			
Fuel and water temperature gauge	•	•	•
Speedo, Tacho, Tripmeter	•	•	•
Oil pressure and charge warning light	•	•	•
Brake warning light	•	•	•
Low fuel warning	•	•	•
Door ajar warning light	•	•	•
Seatbelt warning lamp	•	•	•
Sub fuel tank gauge	•	•	•
Digital clock	•	•	•
4WD indicator light	•	•	•
Glow indicator	•	•	•
Sediment filter warning lamp	•	•	•
Illuminated power window switch	•	•	•

Safety			
Dual SRS airbags	•	•	•
Collapsible steering column	•	•	•
Door side intrusion bars	•	•	•
Halogen headlamps	•	•	•
Laminated windscreen	•	•	•
Day/night rear view mirror	•	•	•
Intermittent front wipers	•	•	•
Variable intermittent front wipers	•	•	•
Adjustable headrests	•	•	•

⁴Maximum tyre load is 2,270kg or 2,360kg with 265/75R16 LT tyres

PATROL CAB CHASSIS

SHIFT the way you move



Specifications (Cont)

	DX Coil 3.0 litre intercooled turbo diesel	DX Leaf 3.0 litre intercooled turbo diesel	ST Coil 3.0 litre intercooled turbo diesel
Exterior			
Over fender flares	•	Opt	•
Side steps			•
Lockable fuel filler caps	•	•	•
Front mudflaps	•	•	•
Front & rear towing hooks	•	•	•
Door handles	Black	Black	Black
Door mirrors	•	•	•
Colours			
White	•	•	•
Pewter Grey*	•	•	•
Golden Sands*	•	•	•
Big Red	•	•	•
Warranty			
3 year/100,000kms	•	•	•
3 year 24hour roadside assist	•	•	•
Genuine Nissan Extended Warranty	Opt	Opt	Opt

*Indicates a metallic colour which is available at extra cost.

Opt Optional Not available • Standard

†Towing capacity is subject to towbar/towball capacity. The capacity may be reduced if a non-Nissan Genuine towbar is fitted.

LEAF SPRING TOWBALL DOWNLOAD:

Towball Download must not exceed 250kg at GVM.** To increase the towball download above 250kg, the vehicle mass needs to be decreased as per the following table.

Towball download	Vehicle Mass
250kg	GVM** (All Variants)
300kg	Reduce loaded vehicle mass below GVM** by 85kg
320kg	Reduce loaded vehicle mass below GVM** by 120kg

** GVM = Gross Vehicle Mass. Includes the driver, 1-2 passengers (refer seating capacity), full fuel tank and payload.

COIL SPRING TOWBALL DOWNLOAD:

Towball Download must not exceed 100kg at GVM.** To increase the towball download above 100kg, the vehicle mass needs to be decreased as per the following table.

Towball download	Vehicle Mass
100kg	GVM** (All Variants)
150kg	Reduce loaded vehicle mass below GVM** by 115kg
200kg	Reduce loaded vehicle mass below GVM** by 200kg
250kg	Reduce loaded vehicle mass below GVM** by 290kg
300kg	Reduce loaded vehicle mass below GVM** by 365kg
320kg	Reduce loaded vehicle mass below GVM** by 400kg

** GVM = Gross Vehicle Mass. Includes the driver, 1-2 passengers (refer seating capacity), full fuel tank and payload.

Dimensions

See specification pages for dimensions of all models.

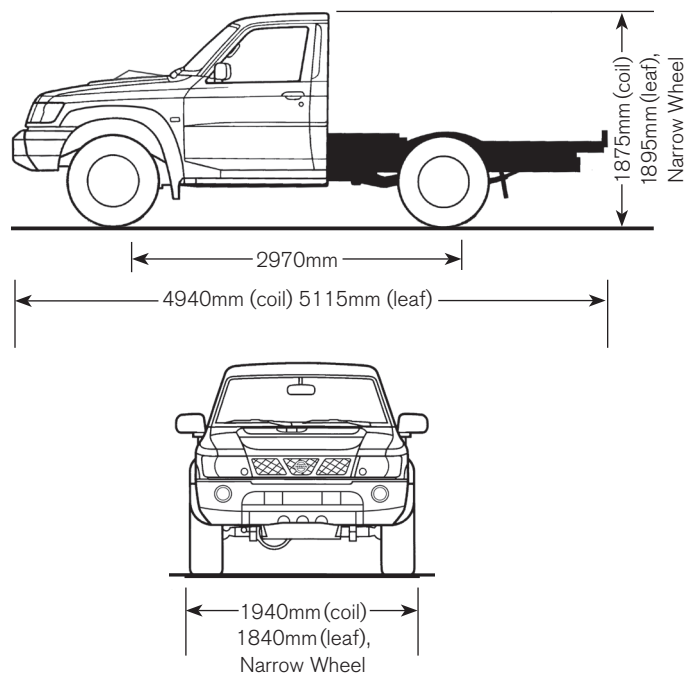

Genuine Nissan Extended Warranty

To find how easily you can extend your new vehicle warranty, ask your Nissan Dealer or phone 1800 035 035 during normal business hours. Good for you, great for your Nissan.



All illustrations, information and specifications presented and referred to in this brochure were correct at the time when this brochure was approved for printing. The colours in the photographs may vary from actual colours. However, Nissan Motor Co (Australia) Pty. Ltd. reserves the right, subject to the laws of Australia and/or the regulations of any competent authority which may apply from time to time, at its discretion at anytime and without prior notice to discontinue or change the models, features, specifications, designs and prices of the products referred to in this brochure and any optional equipment therefore without incurring any liability whatsoever to any purchaser or prospective purchaser of any such products. Some of the items referred to herein are optional at extra cost. Some options may be required in combination with other options. Always consult your Nissan Dealer for the latest information on models, specifications, features, prices, options and availability. Nissan Motor Co (Australia) Pty. Ltd. ACN 004 663 156. 2008MY. July 2009